

# iControls® TL96-COM1-YL Installation Guide

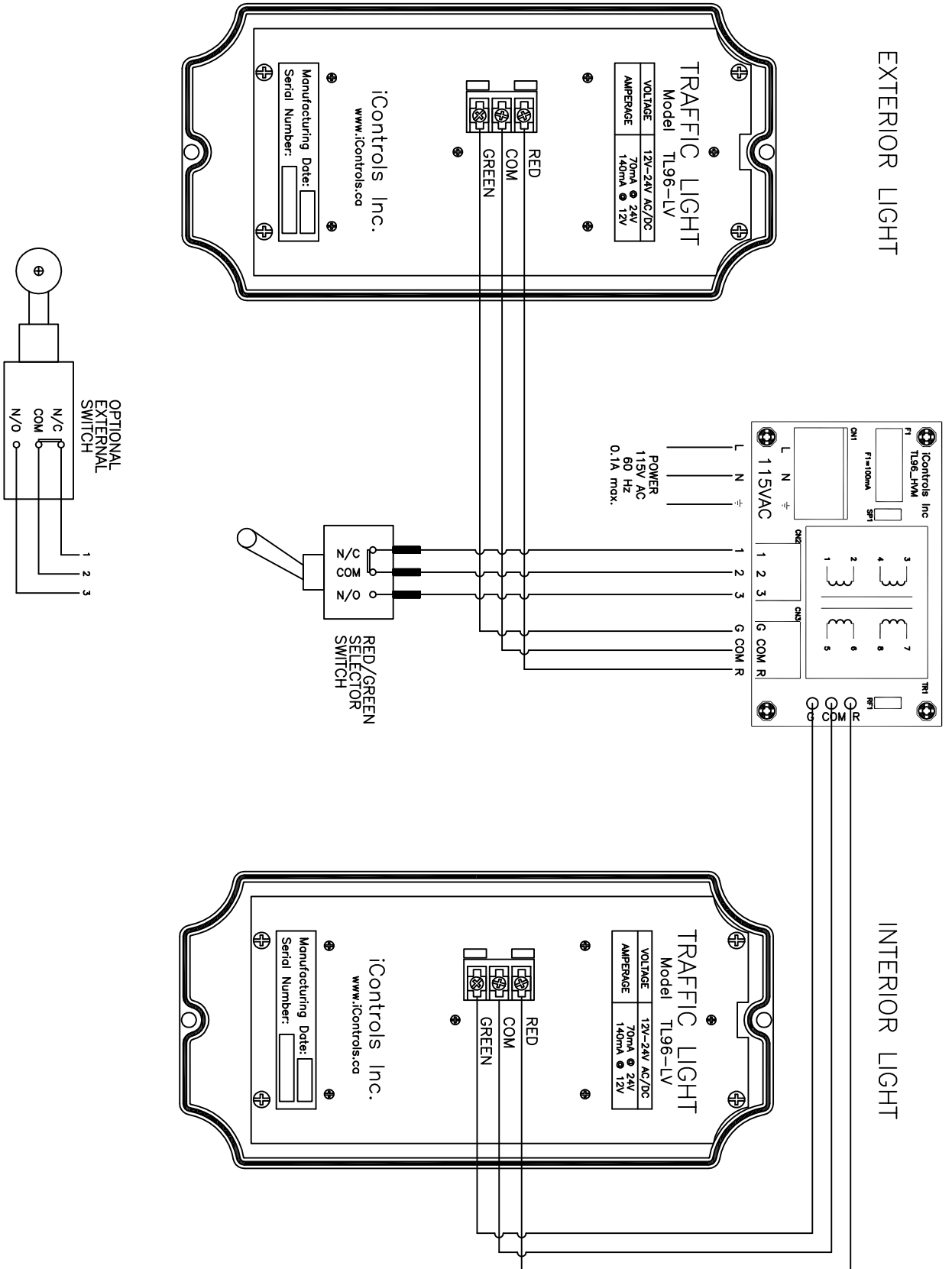

1. Disassemble the front cover from the housing by removing the two provided cover mounting screws (5/8" stainless steel 8-32 thread).
2. Install wall anchors that accept up to 5/16" thread screws (not supplied) using the mounting dimensions on the reverse of this page as reference, in preparation to fasten the enclosure to the wall.
3. Run and mount conduit (not provided) through or up the wall to meet either the back center or bottom of the Housing, and remove the appropriate 7/8" knockout.

**DO NOT CONNECT  
CONDUIT/WIRING  
THROUGH THE TOP OR  
SIDE OF THE ENCLOSURE.**

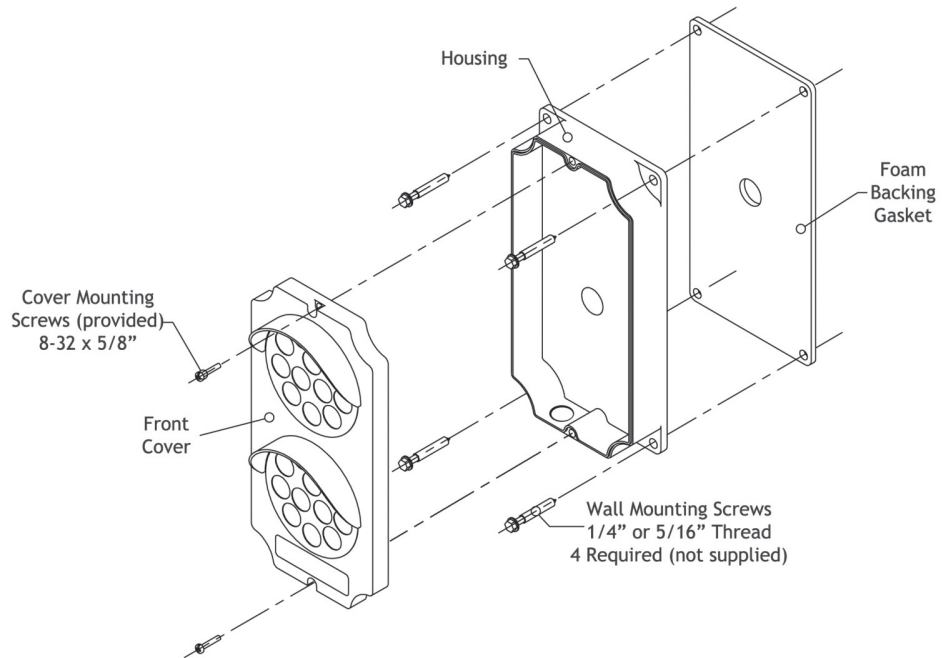

4. Mount the rear foam-backing gasket and secure the enclosure to the wall using 4 (four) 1/4" or 5/16" thread stainless steel wall-mounting screws (not provided), and connect the conduit to the enclosure using a suitable connector.
5. Run the wiring and then connect to the clearly marked terminals on the rear of the front cover of the light (see front cover inside view on reverse for reference).
6. Fasten the light to the mounted enclosure using the cover mounting screws.

### Available Replacement Parts

- Housing base, yellow
- Housing base, black
- Front cover, yellow
- Front cover, black
- Red lens
- Green lens
- Printed circuit board, 115Vac
- Printed circuit board, 12/24V
- Foam-backing gasket
- Rope gasket for front cover
- Circular gasket for lens
- Cover mounting screws
- PC board mounting screws
- Lens mounting screws



**Contact  
iControls  
for Details**